

REV.	DESCRIPTION	ECN NO.	DATE	DRAWER
E	Modified by Customer Design	EC0601038	01/18/2006	Edsen
F	Add Part No.	EC0604021	04/18/2006	Tom
G	Add Plating Option $\triangle G \times 1$	EC0909042	09/15/2009	Hyde

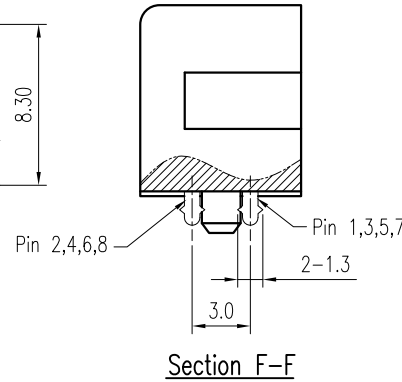
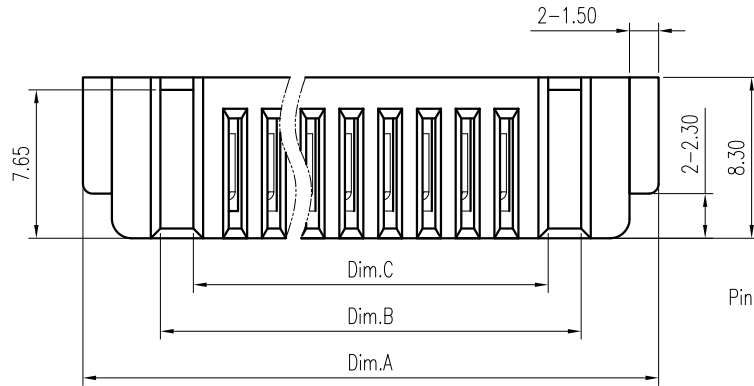

Notes:

- Material :
Housing : Thermoplastic UL 94V-0, Black
Terminal : Copper Alloy
- Finish :
Terminal : Selected Gold on Contact Area,
G/F on Solder Tails,
Both over 40u" Ni Under-plated Overall

3. Order Information :

SAO-030 XX -11T X

T : RoHS (for High Temperature)

Amount of Pins

04 : 4 Pins

5

09 : 9 Pins

Plating

2 : 2u" Gold on Contact Area

3 : 5u" Gold on Contact Area

$\triangle G$ 5 : 15u" Gold on Contact Area

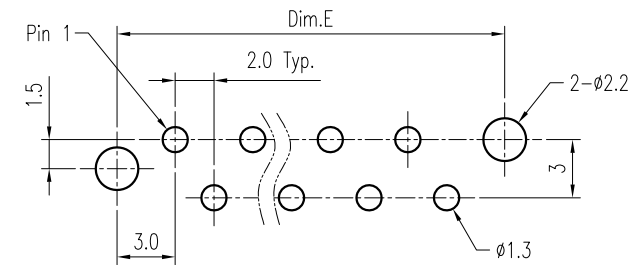
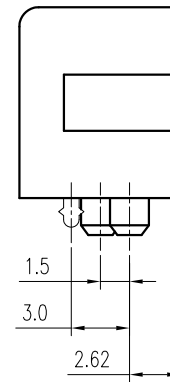
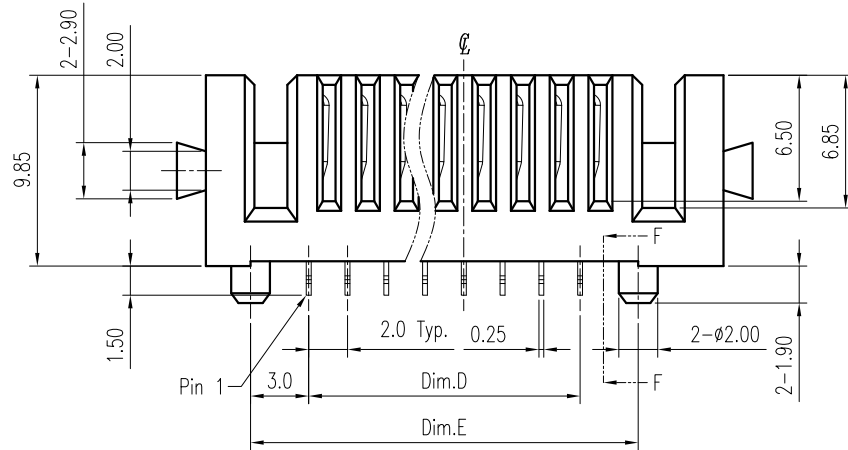

Recommended P.C.B. Layout
Layout Tolerance = ± 0.05 mm

Dimension Information:

Part No.	Dim.	Amount of Pins	Dim.A	Dim.B	Dim.C	Dim.D	Dim.E
TSAO-03004-11TX	4	4	21.7	13.7	10.3	6.0	12.0
TSAO-03005-11TX	5	5	23.7	15.7	12.3	8.0	14.0
TSAO-03006-11TX	6	6	25.7	17.7	14.3	10.0	16.0
TSAO-03007-11TX	7	7	27.7	19.7	16.3	12.0	18.0
TSAO-03008-11TX	8	8	29.7	21.7	18.3	14.0	20.0
TSAO-03009-11TX	9	9	31.7	23.7	20.3	16.0	22.0

DIMENSION IN mm [inch]			
Tolerance unless otherwise specified			
X.	\pm	--	X.* $\pm 10'$
X.X	\pm	0.38	X.X* $\pm 5'$
X.XX	\pm	0.25	X.XX* $\pm 2'$
X.XXX	\pm	0.13	X.XXX* \pm

CEN 欣訊科技股份有限公司
CEN LINK CO., LTD.
CUSTOMER DRAWING

Approver:

Checker:

Drawer: **Hyde**

09/15/2009

Title 2.0mm Pitch Battery Conn.
Female Type

Dwg No. TSAO-030XX-11TX

File No. P03002

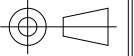

Scale: 2.5 : 1

Size: A 4

Rev : G

Sheet: 1 / 1