

REV.	DESCRIPTION	ECN NO.	DATE	DRAWER
A	New Released		08/13/2009	Steven

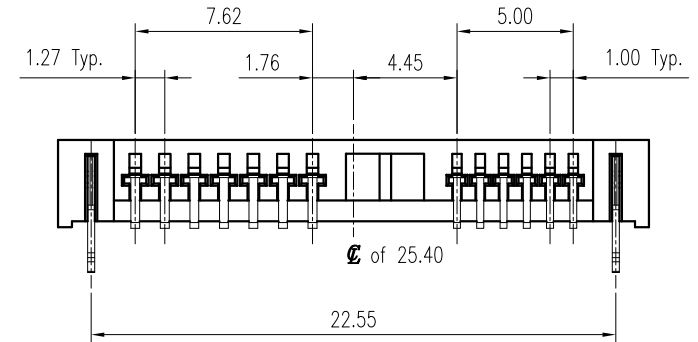

Notes: 1. Material :
Housing : Thermoplastic UL 94V-0, Black
Terminal : Copper Alloy
Forklock : Copper Alloy
2. Finish :
Terminal : Selected Gold on Contact Area, Gold Flash on Solder Tails, Both over 50u" Min. Ni Under-plated Overall
3. Order Information :

T BNO-01221-10 X X A
T : RoHS(for High Temperature) Plating
1 : Gold Flash on Contact Area
2 : 3u" Min. Gold on Contact Area
3 : 5u" Min. Gold on Contact Area
4 : 10u" Min. Gold on Contact Area
5 : 15u" Min. Gold on Contact Area
Packing
T : Tube
1 : Cap + Tube
2 : Cap + Reel

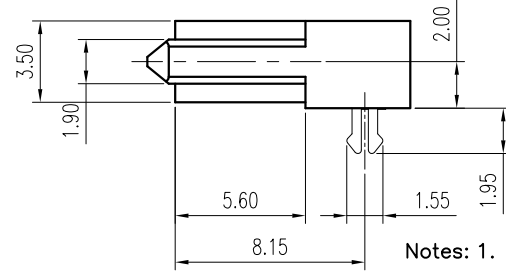
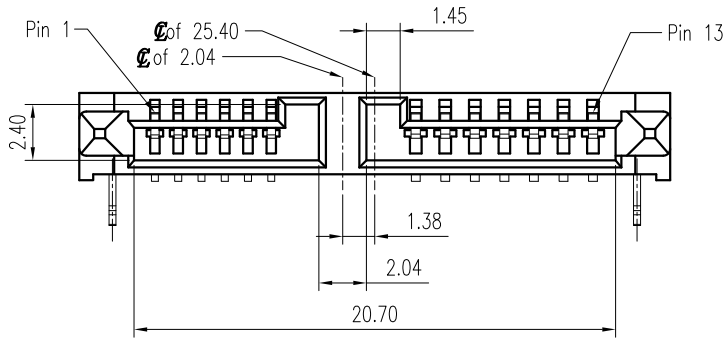
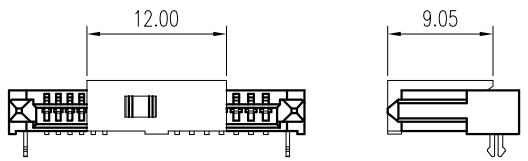
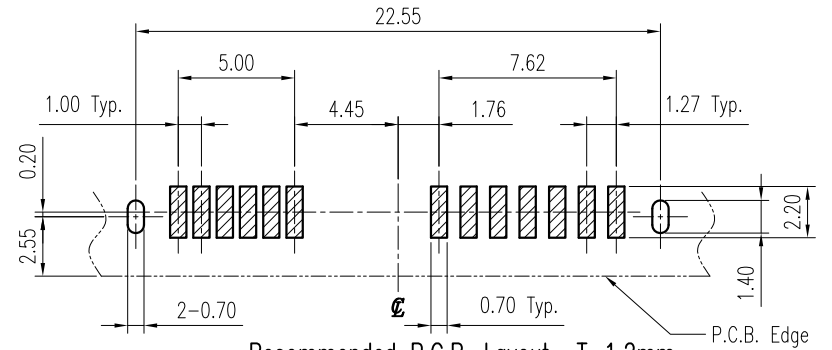
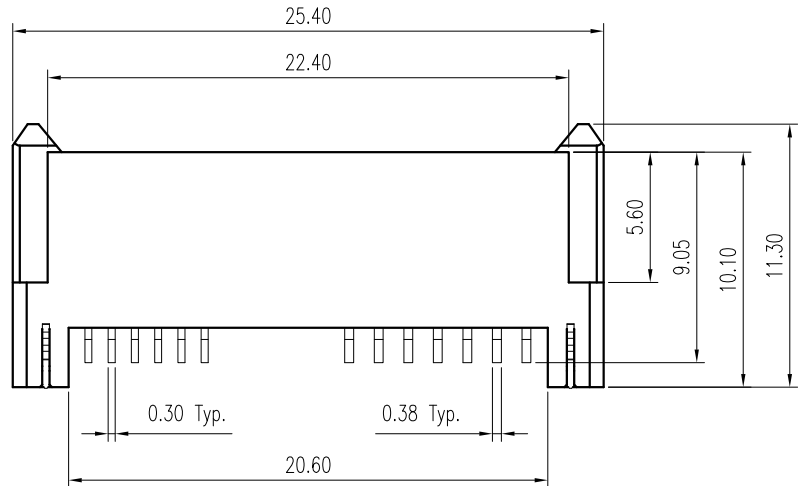

With Cap
Scale 1.5:1

DIMENSION IN mm [inch]	
Tolerance unless otherwise specified	
X. \pm	X.* $\pm 10'$
X.X ± 0.38	X.X* $\pm 5'$
X.XX ± 0.25	X.XX* $\pm 2'$
X.XXX ± 0.13	X.XXX* \pm

CEN 欣訊科技股份有限公司
CEN LINK CO., LTD.
CUSTOMER DRAWING

Title	H=2.0mm Slimline SATA	Scale: 3 : 1
Dwg No.	TBNO-01221-10XXA	Size: A 4
File No.	PO9018	Rev : A
Apprver:	Checker:	Drawer: Steven
		08/13/2009
		Sheet: 1 / 1