

REV.	DESCRIPTION	ECN NO.	DATE	DRAWER
A	New Release		02/20/2008	Alan

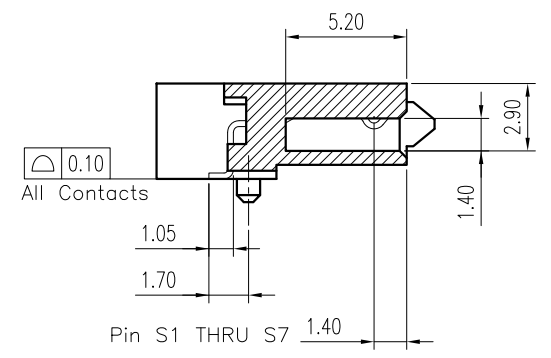

Section A-A

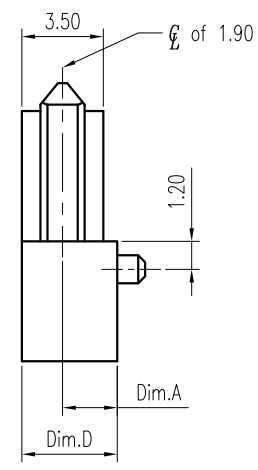
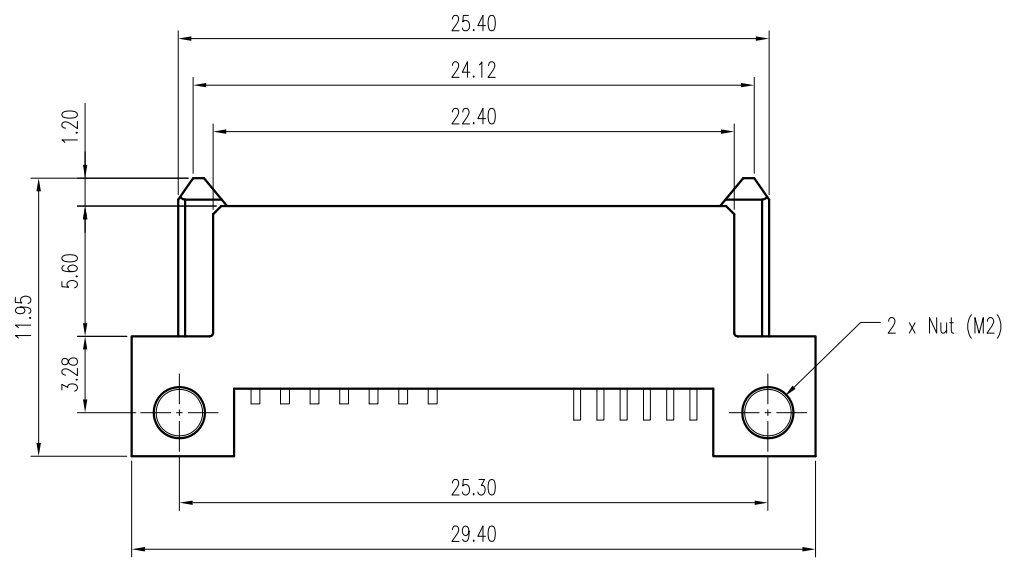
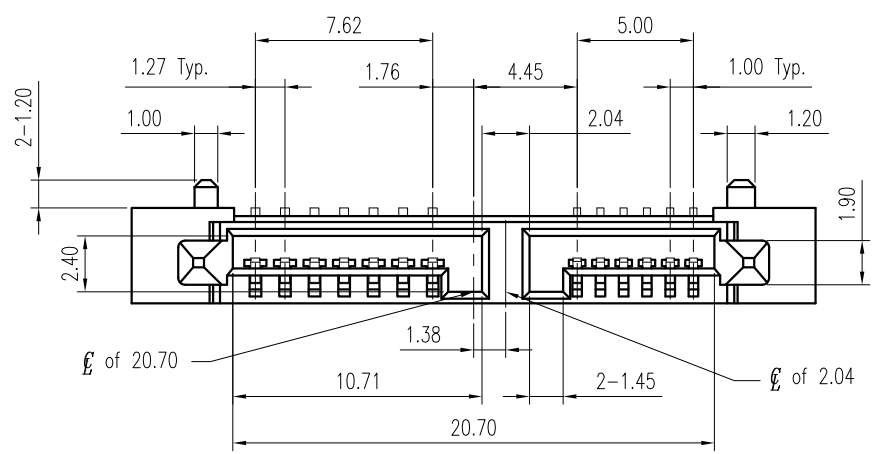
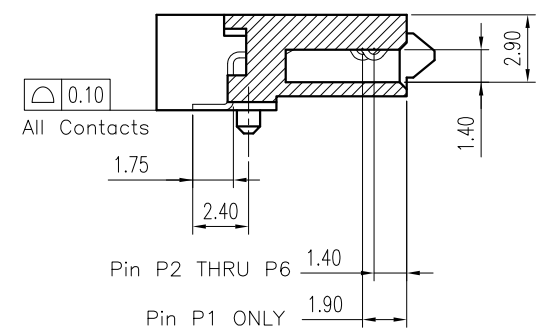

Section B-B

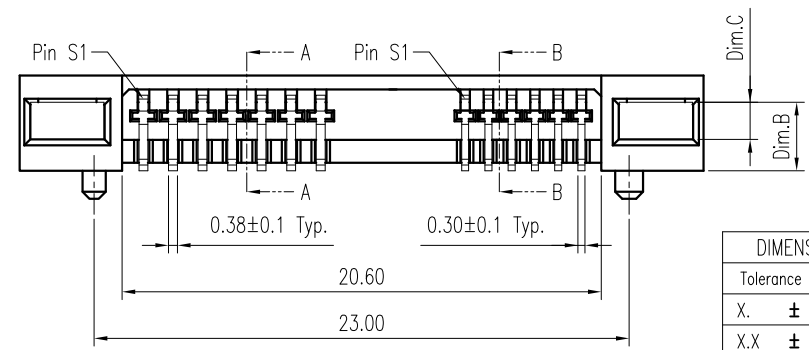

DIMENSION IN mm [inch]	
Tolerance unless otherwise specified	
X. ±	X.* ± 10'
X.X ± 0.38	X.X* ± 5'
X.XX ± 0.25	X.XX* ± 2'
X.XXX ± 0.13	X.XXX* ±

**CEN** 欣訊科技股份有限公司  
CEN LINK CO., LTD.

Approver: \_\_\_\_\_ Checker: \_\_\_\_\_

Title **SLIMLINE SATA RECPACLE  
BOTTOM MOUNT WITH NUT(SMT)**  
Dwg No. **TBNO-01122-X0XX**  
File No. **PO7016**

Drawer: **Alan**  
Date: **02/20/2008**

Scale: **3 : 1**  
Size: **A 4**  
Rev : **A**  
Sheet: **1 / 2**

REV.	DESCRIPTION	ECN NO.	DATE	DRAWER
A	New Release		02/20/2008	Alan

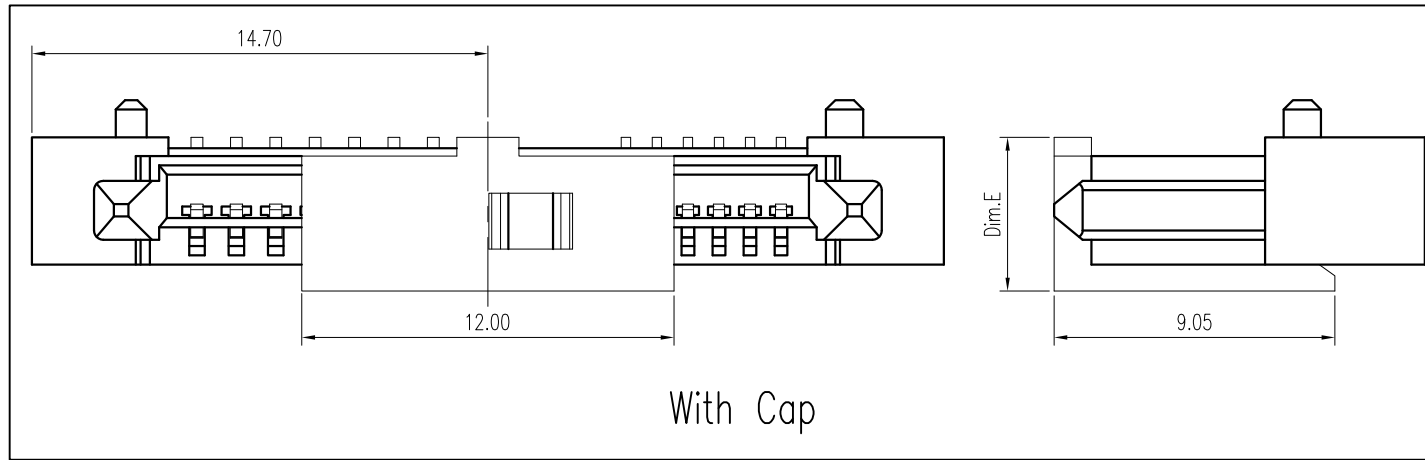

Part No.	Dim.	Dim.A	Dim.B	Dim.C	Dim.D	Dim.E
TBNO-01122-10XX		1.85	2.45	1.20	3.60	4.45
* TBNO-01122-20XX		2.35	2.95	1.60	4.10	4.95
TBNO-01122-30XX		2.85	3.45	1.60	4.60	5.45
TBNO-01122-40XX		3.35	3.95	1.60	5.10	5.95
TBNO-01122-50XX		3.85	4.45	1.60	5.60	6.45
TBNO-01122-60XX		4.35	4.95	1.60	6.10	6.95
TBNO-01122-70XX		4.85	5.45	1.60	6.60	7.45
TBNO-01122-80XX		5.35	5.95	1.60	7.10	7.95
TBNO-01122-90XX		5.85	6.45	1.60	7.60	8.45
TBNO-01122-A0XX		8.25	8.85	1.60	10.00	10.85

(\* = Mass Product)

Notes:

- Material :  
Housing : Thermoplastic UL 94V-0, Black  
Terminal : Copper Alloy  
Nut : Brass
- Finish :  
Terminal : Selected Gold on Contact Area, Gold Flash on Solder Tails, Both over 50u" Min. Ni Under-plated Overall  
Nut : 40u" Ni Overall
- Order Information :

TBNO-01122-X 0 X X  
Type                      Plating  
1 : Dim.A = 1.85mm      2 : 2u" Min. Gold on Contact Area  
2                              3 : 5u" Min. Gold on Contact Area  
A : Dim.A = 8.25mm      4 : 10u" Min. Gold on Contact Area  
                                    5 : 15u" Min. Gold on Contact Area  
                                    6 : 20u" Min. Gold on Contact Area

Packing  
T : Tube  
1 : Tube + Cap  
2 : Reel + Cap

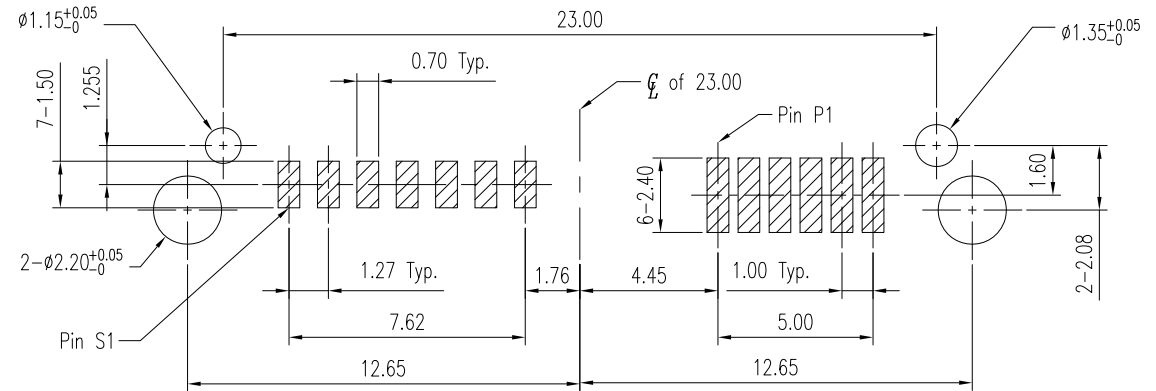

Recommended P.C.B. Layout  
Layout Tolerance = ± 0.05 mm

DIMENSION IN mm [inch]	
Tolerance unless otherwise specified	
X. ±	X.* ± 10'
X.X ± 0.38	X.X* ± 5'
X.XX ± 0.25	X.XX* ± 2'
X.XXX ± 0.13	X.XXX* ±

**CEN** 欣訊科技股份有限公司  
CEN LINK CO., LTD.  
CUSTOMER DRAWING

Title SLIMLINE SATA RECEPTACLE  
BOTTOM MOUNT WITH NUT(SMT)  
Dwg No. TBNO-01122-X0XX  
File No. P07016

Approver:

Checker:

Drawer: Alan

02/20/2008

Scale: 2 : 1  
Size: A 4  
Rev : A  
Sheet: 2 / 2