

REV.	DESCRIPTION	ECN NO.	DATE	DRAWER
A	New Release		10/05/2007	Meill

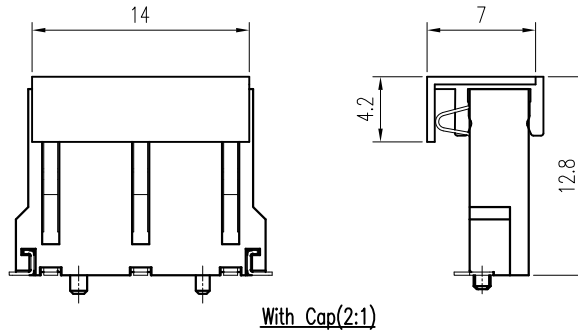
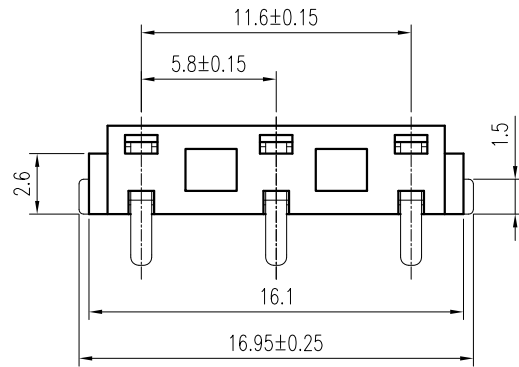

Notes:

- Material :  
 Housing : Thermoplastic UL 94V-0, Black  
 Terminal : Copper Alloy  
 Fork : Copper Alloy  
 CAP : Thermoplastic UL 94V-0, Black
- Finish :  
 Terminal : Selected Gold on Contact Area, Gold Flash on Solder Tails, Both over 50u" Min. Ni Under-plated Overall  
 Fork : 1u" Min. Gold over 50u" Min. Ni
- Order Information :

TSN1-03100-03 X X

Plating

- T : Tube
- 1 : Tube + CAP
- 2 : Reel + CAP

Plating

- 1 : 1u" Min. Gold on Contact Area
- 4 : 10u" Min. Gold on Contact Area

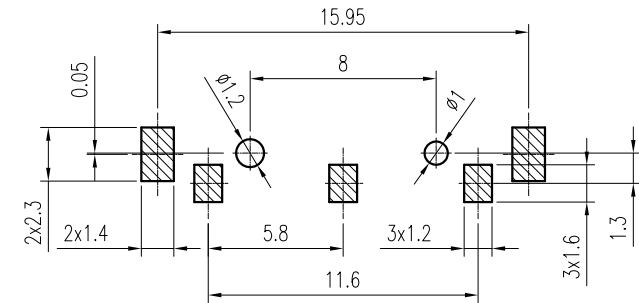
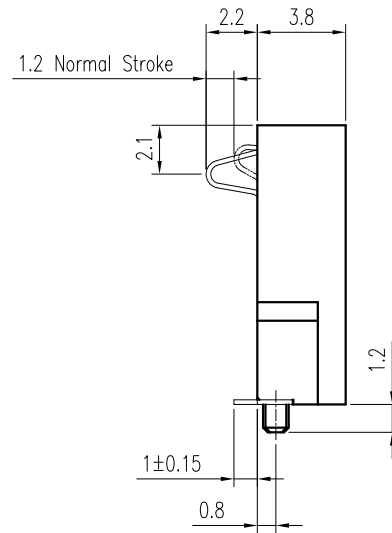
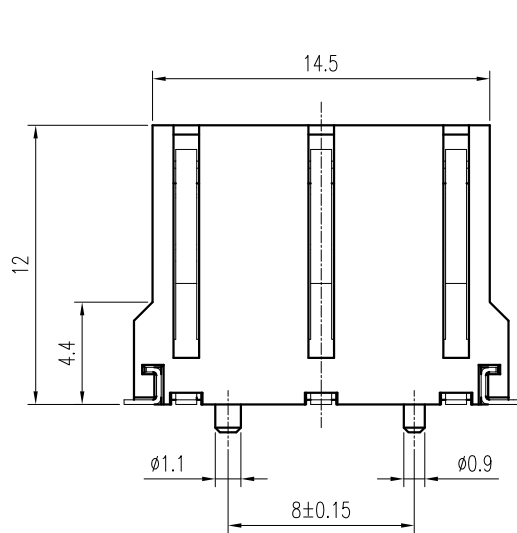

Recommended P.C.B. Layout  
 Layout Tolerance = ± 0.05 mm

DIMENSION IN mm [inch]	
Tolerance unless otherwise specified	
X. ± 0.38	X.' ± 10'
X.X ± 0.20	X.X' ± 5'
X.XX ± 0.13	X.XX' ± 2'
X.XXX ±	X.XXX' ±

**CEN** 欣訊科技股份有限公司  
 CEN LINK CO., LTD.

Approver:

Checker:

Drawer: **Meill**

10/05/2007

Title 5.8mm Pitch Spring Battery Conn.

Dwg No. TSN1-03100-03XX

File No. P07012

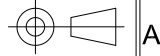

Scale: 3 : 1

Size: A 4

Rev : A

Sheet: 1 / 1